



FORNO GENESI PER PIZZA  
caratteristiche principali











MUCH MORE THAN A PIZZA OVEN  
very versatile oven fully equipped with

- pizza tray

- wire shelf

- deep tray

you can cook and grill  
food like Lasagna, cakes,  
american pizza or even  
steaks





- telescopic liners → safety first!

- easy-to-remove side rails → easy cleaning





# TECHNICAL FEATURES

model	size (cm)	inside material	n. functions	cavity capacity (l)	kW	kW	kW	kW	kW	max kW
										
GFE6-P	59,5 X 57,1 X 45	s.steel Aisi 304	4	34	0,03	2,08	0,88	1,23	1,95	2,08

# INSTALLATION DRAWING

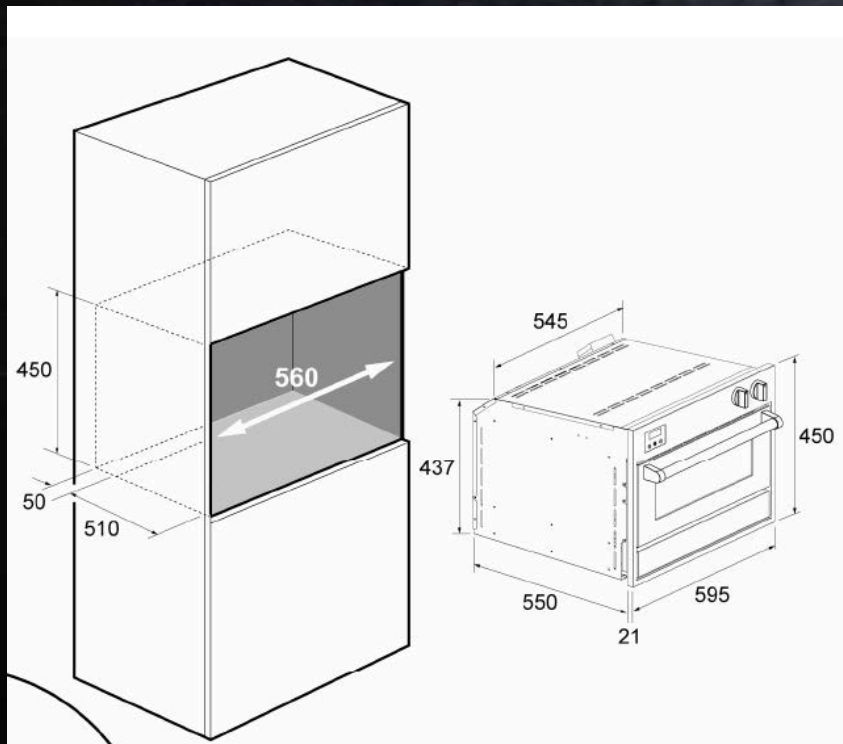

\* suggested position : 85 cm from the floor in a 210 cm height column



**steel**  
stile in cucina

[www.steel-cucine.com](http://www.steel-cucine.com)